

COMBINATION CURB & GUTTER
TYPE 'B'

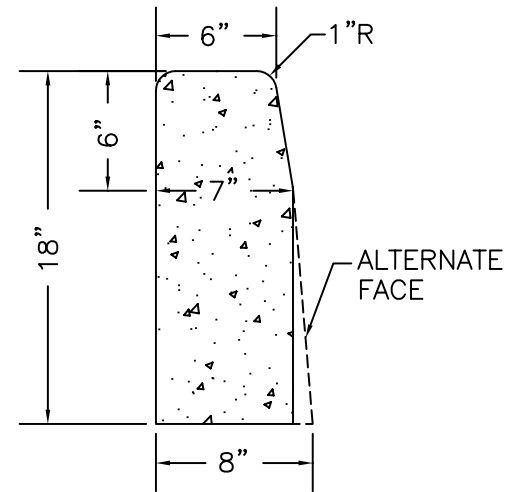

CURB-TYPE 'A'

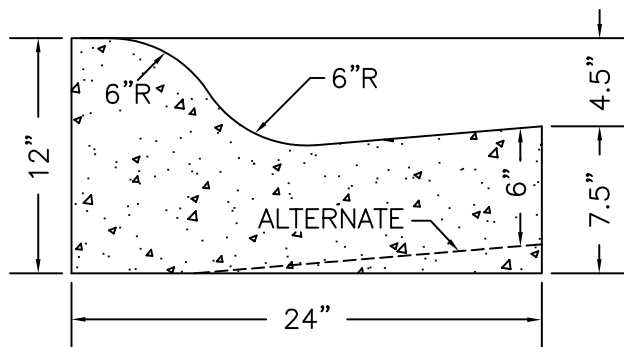

COMBINATION CURB & GUTTER
TYPE 'C'

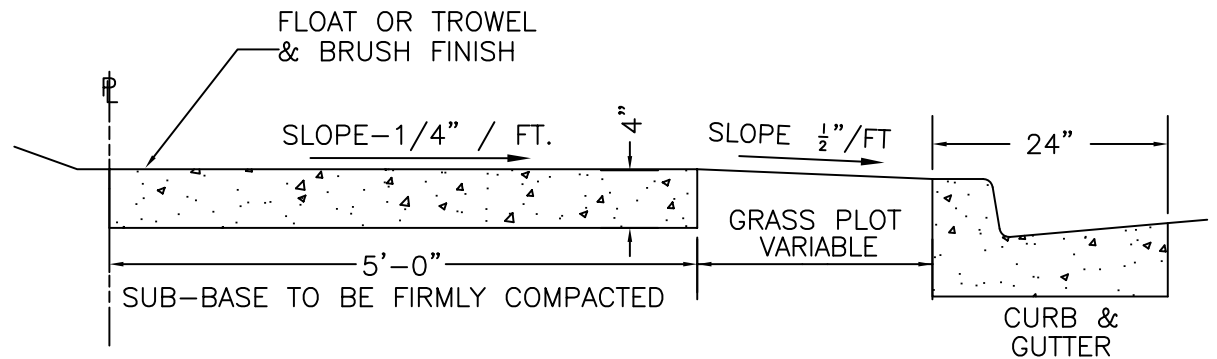

TYPICAL SECTION-SIDEWALK, CURB AND GUTTER

CITY OF SPRINGFIELD, OHIO DEPARTMENT OF ENGINEERING	
CURBING & WALK DETAILS	DATE JUL 98
STANDARD DRAWING CU-1	
APPROVED _____	CITY ENGINEER

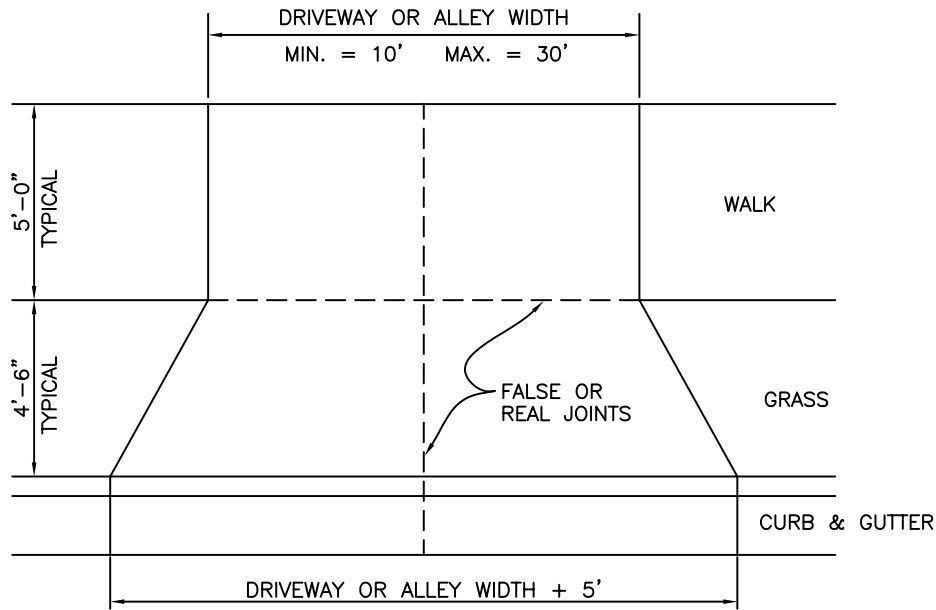

PLAN

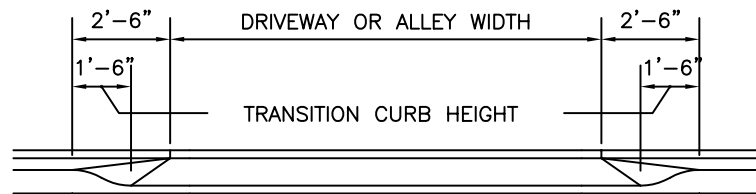

ELEVATION

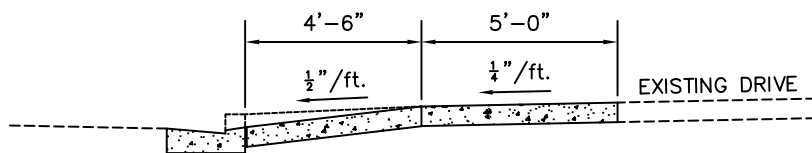

SECTION

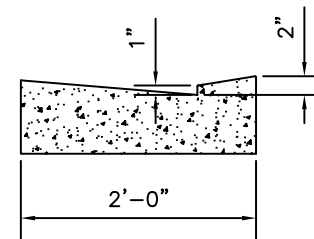

DROP CURB DETAIL

NOTES:

CONDITIONS WHICH MAY WARRANT VARIATIONS FROM THESE SPECIFICATIONS MUST BE REVIEWED BY THE ENGINEER, AND CHANGES APPROVED BY THE ENGINEER.

CONCRETE SHALL BE CLASS C (4000 LB)

CONCRETE THICKNESS SHALL BE 6" FOR RESIDENTIAL DRIVES AND 8" FOR COMMERCIAL DRIVES AND ALLEYS.

SPACING OF FALSE OR REAL JOINTS NOT TO EXCEED 5 FEET.

EXPANSION JOINTS SHALL BE PLACED AS PER ITEM 608.03

CURB AND GUTTER MUST BE CONSTRUCTED SEPARATELY FROM THE DRIVEWAY OR ALLEY APPROACH.

CITY OF SPRINGFIELD, OHIO DEPARTMENT OF ENGINEERING	
DRIVE AND ALLEY DETAIL	DATE JUL 98
STANDARD DRAWING DW-1	
APPROVED _____	CITY ENGINEER

\\itfs007.dot.state.oh.us\Roadway\Standards\Publications\LDM\Distributions\ldm_2020-07-17\working\STANDARD DWG BP-7.1 Updates\3-18-20 BP-7.1_2018-07-20.dgn Sheet 1 7/13/2020 10:30:44 AM

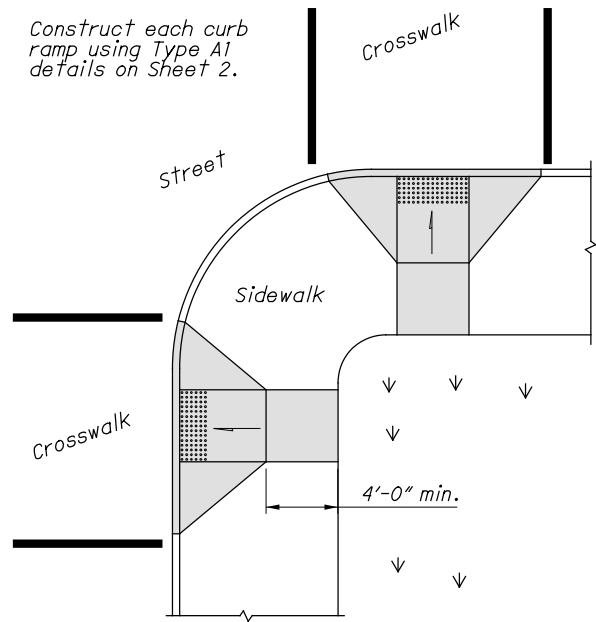

Construct each curb ramp using Type A1 details on Sheet 2.

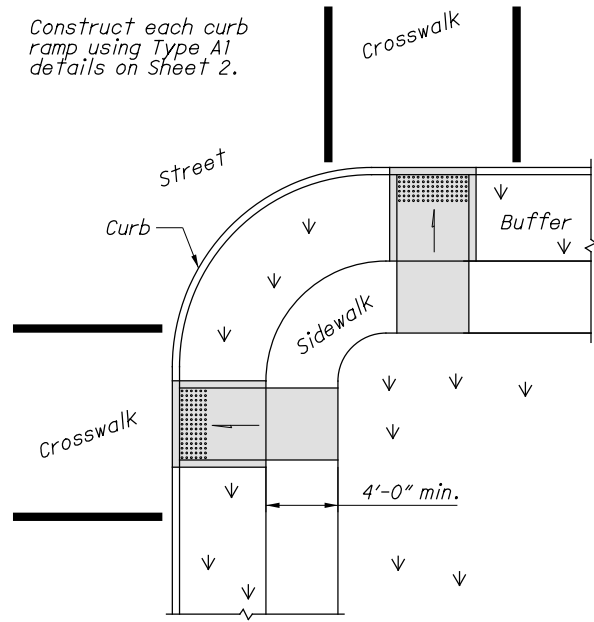

Construct each curb ramp using Type A1 details on Sheet 2.

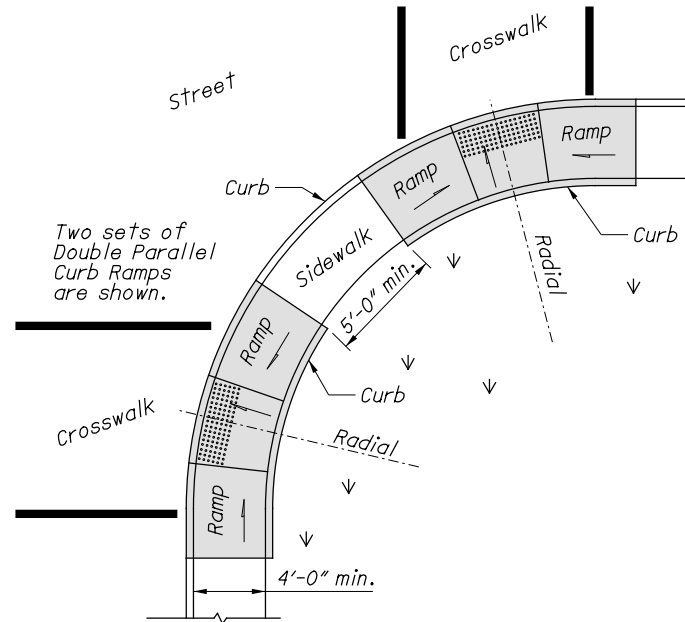

Two sets of Double Parallel Curb Ramps are shown.

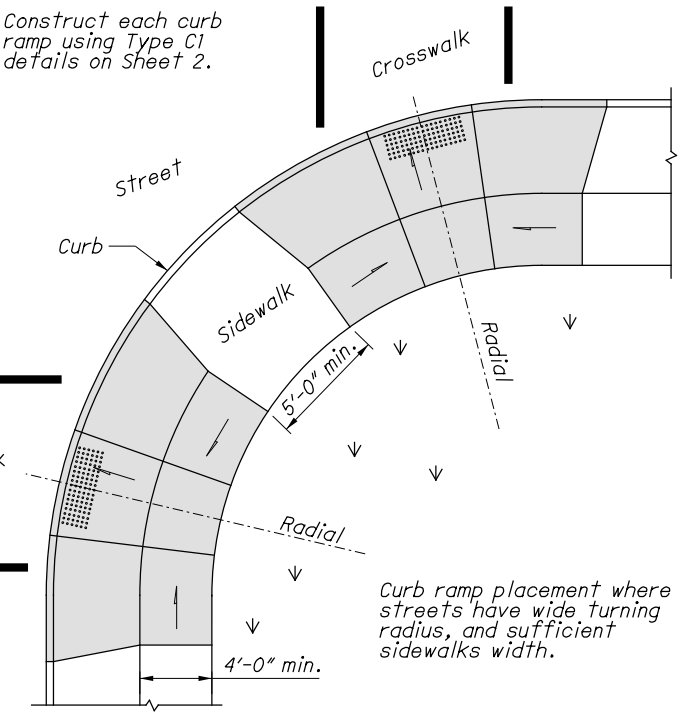

Construct each curb ramp using Type C1 details on Sheet 2.

Curb ramp placement where streets have wide turning radius, and sufficient sidewalks width.

PERPENDICULAR CURB RAMPS

PARALLEL CURB RAMPS

COMBINATION CURB RAMPS

PREFERRED CONSTRUCTION PLACEMENT

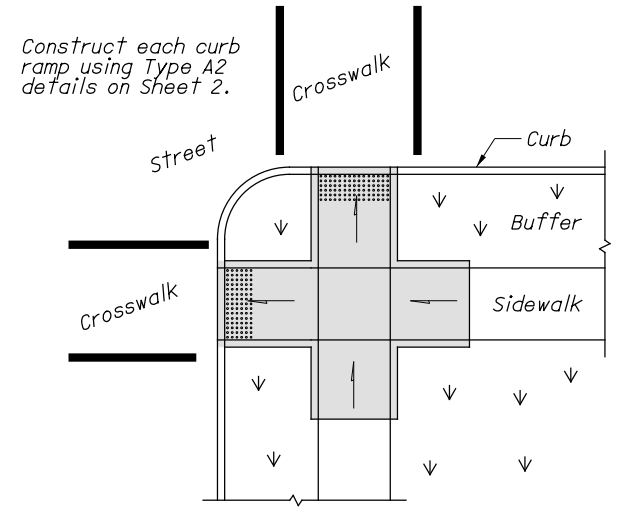

Construct each curb ramp using Type A2 details on Sheet 2.

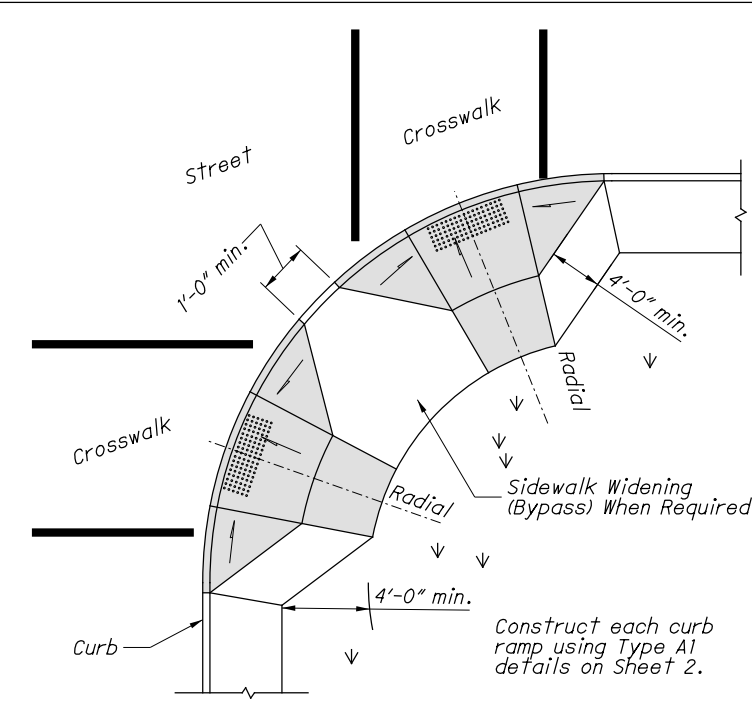

Acceptable design on corners with wide turning radius where user is able to maneuver within crosswalk limits so as not to encroach into adjacent traveled lanes.

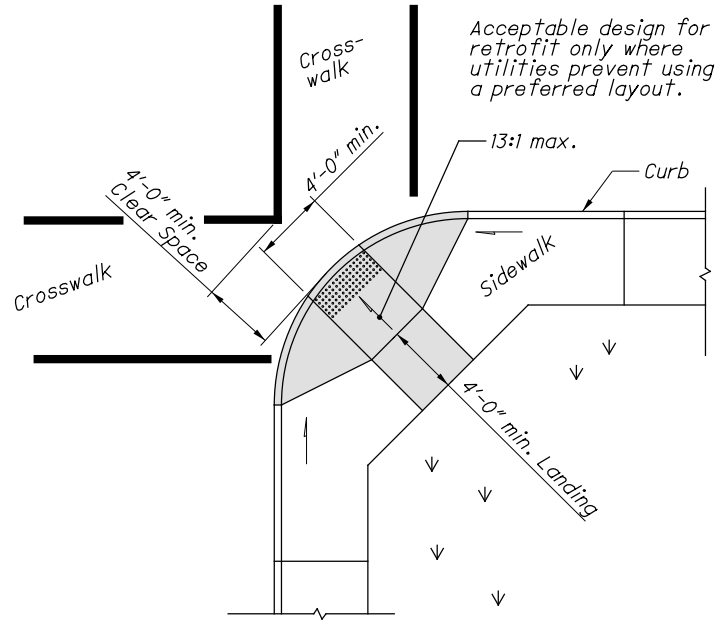

Acceptable design for retrofit only where utilities prevent using a preferred layout.

Use this design only for existing walks, and when site constraints prohibit other designs. The diagonal Type D ramp may be constructed as either a Perpendicular, Parallel or Combination curb ramp type. Avoid using where curb radii are less than 20'-0".

PERPENDICULAR RAMPS

DIAGONAL RAMP (Type D)

ACCEPTABLE CONSTRUCTION PLACEMENT

NOTES

GENERAL: This drawing shows curb ramp types details and placement examples for curb ramp construction, including the installation of detectable warnings.

Curb ramp types are shown on Sheet 2 and include Perpendicular, Parallel, and Combined types as specified to be constructed in the locations shown on the project plans.

Curb ramps added to an existing intersection or walk should be individually detailed on the project plans to assure that the design is appropriate for site constraints and all items can be constructed to ADA standards. The contractor may adjust the placement of curb ramps if existing field conditions warrant with the approval of the Engineer.

PAYMENT: Measure and pay for the ramp area within the shaded limits of this drawing as Item 608 Curb Ramp, Square Foot. This includes the cost of any curb or curb and gutter, detectable warnings, landing areas and any additional materials, installation, grading, forming, and finishing required within the shaded area.

Work beyond the shaded ramp/landing area is paid for as curb (609) and walk (608). Removal of existing curb, walk (or existing curb ramps) are paid under Item 202.

For at-grade crossing locations where only detectable warnings are required in order to achieve ADA compliance, measure and pay for the strip of detectable warnings as Item 608 Detectable Warning, Square Foot. The work to cast the tiles in place will also require removal of existing pavement (Item 202) to the nearest joint, or if no joint exists, a minimum of 4 feet.

STATE OF OHIO DEPARTMENT OF TRANSPORTATION ADMINISTRATOR	REVISION DATE
Brenton Bogard	7-17-2020
STANDARD ROADWAY CONSTRUCTION DRAWING	
NEW CURB RAMPS (with Detectable Warnings)	
OFFICE OF ROADWAY ENGINEERING	
D. Fisher	
SCD NUMBER	
BP-7.1	
THIS DRAWING REPLACES BP-7.1 DATED 7-20-2018.	
1 / 3	

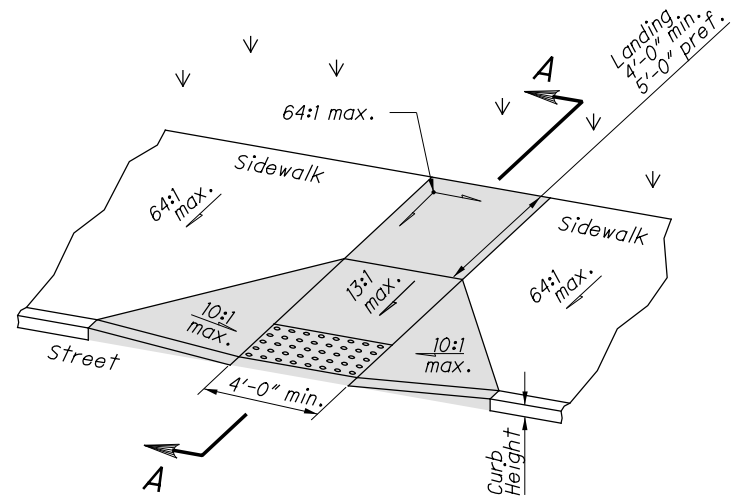

Type A1 (Perpendicular with flared sides)

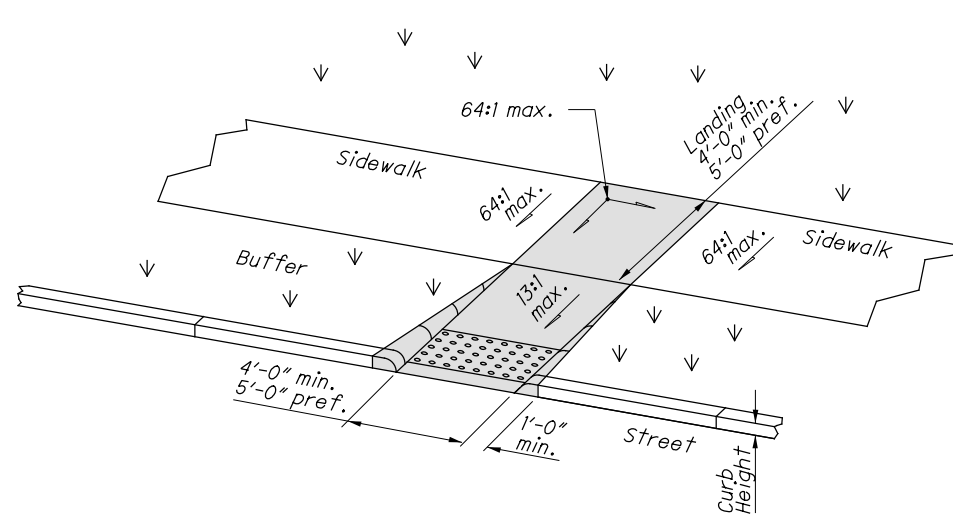

Type A2 (Perpendicular with returned curb)

PERPENDICULAR CURB RAMP DETAILS

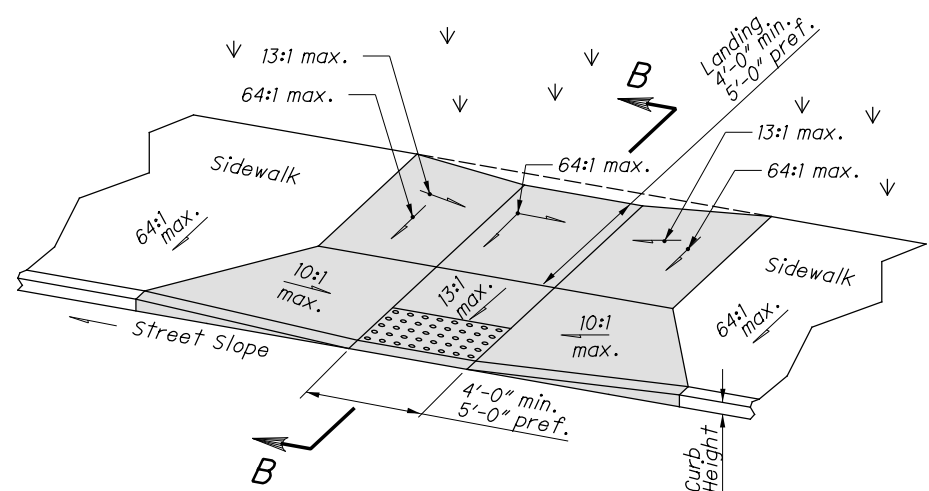

Type C1 (Combined with flared sides)

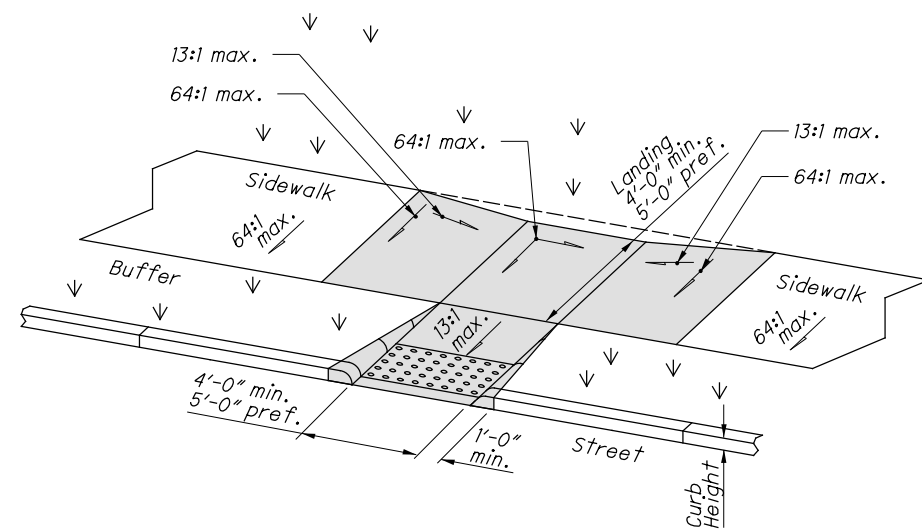

Type C2 (Combined with returned curb)

COMBINED CURB RAMP DETAILS

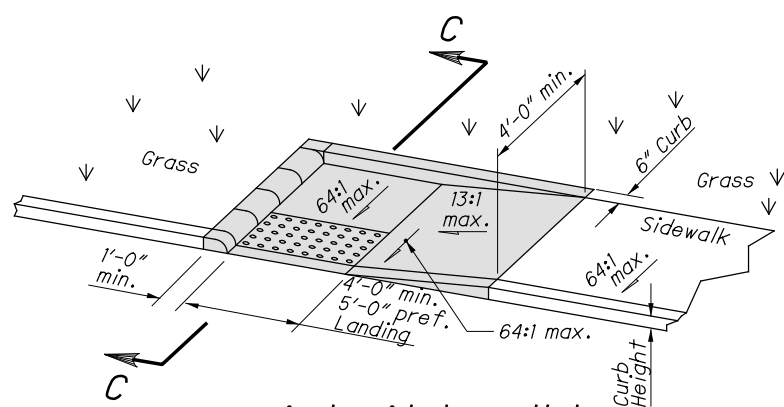

Type B1 (Single sided Parallel)

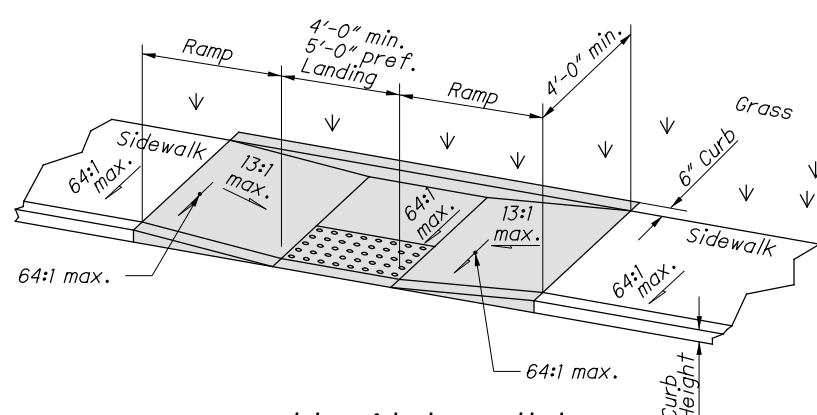

Type B2 (Double sided Parallel)

PARALLEL CURB RAMP DETAILS

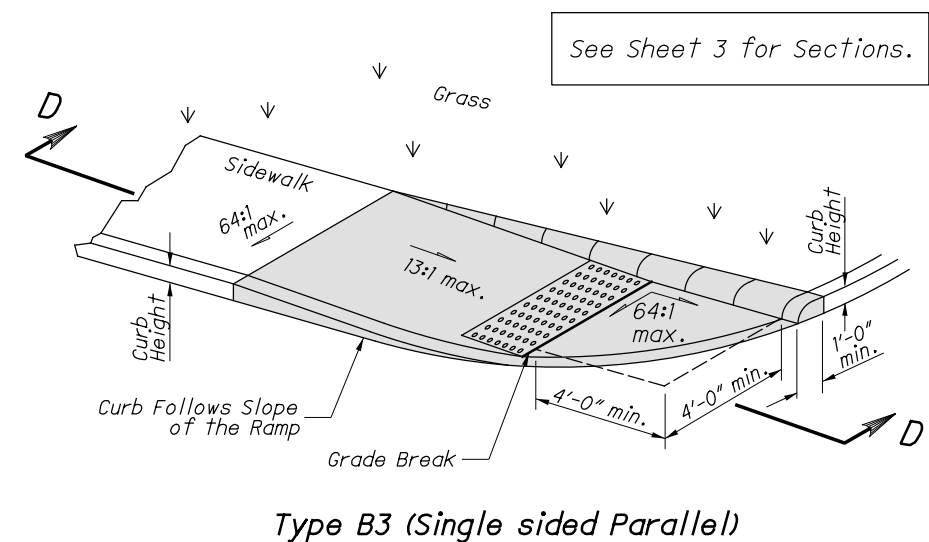

Type B3 (Single sided Parallel)

NOTES CONTINUED

The running slope of the curb ramp shall be a 13:1 maximum or flatter. In existing sidewalks, where the maximum ramp slope is not feasible due to site constraints (e.g. utility poles or vaults, right-of-way limits) it may be reduced as follows:

- A) 10:1 for a max. rise of 6",
- B) 8:1 for a max. rise of 3",
- C) 6:1 over a max. run of 2'-0" for historic areas where a flatter slope is not feasible.

To prevent chasing the grade indefinitely, the transition from existing sidewalk to the shaded curb ramp area is not required to exceed 15 feet in length.

While ramps may be skewed to the crosswalk, the entire lower landing area must fall within the cross walk that the ramp serves and cannot be located in the traveled lane of opposing traffic.

The counter slope of the gutter or street at the foot of a curb ramp, landing, or blended transitions shall be 20:1 or flatter.

The bottom edge of the ramp shall change planes perpendicular to the landing.

The edge of the curb shall be flush with the edge of the adjacent pavement and gutter and surface slopes that meet grade breaks shall also be flush.

Ramp landings shall be 4' min. x 4' min. with a 64:1 or flatter cross slope and running slope.

DETECTABLE WARNINGS: Install Detectable Warnings on each curb ramp with approved materials, as shown on Sheet 3. Install these proprietary products as per manufacturer's written instructions.

DRAINAGE: Contractor is to ensure the base of each constructed curb ramp allows for proper drainage, without exceeding allowable cross slope or ramp slopes. Vertical change in level exceeding 1/8" between the 1) pavement and gutter, and 2) gutter and ramp, are not allowed.

SURFACE TEXTURE: Texture concrete surfaces by coarse brooming transverse to the ramp slopes to be rougher than the adjacent walk.

JOINTS: Provide expansion joints in the curb ramp as extensions of walk joints and consistent with Item 608.03 requirements for a new concrete walk. Provide a 1/2" Item 705.03 expansion joint filler around the edge of ramps built in existing concrete walks. Lines shown on this drawing indicate the ramp edges and slope changes, and do not necessarily indicate joint lines.

See Sheet 3 for Sections.

\\itfs007.dot.state.oh.us\Roadway\Standards\Publications\LDM\Distributions\ldm_2020-07-17\working\STANDARD DWG BP-7.1_2018-07-20.dgn Sheet 3 7/13/2020 10:36:47 AM

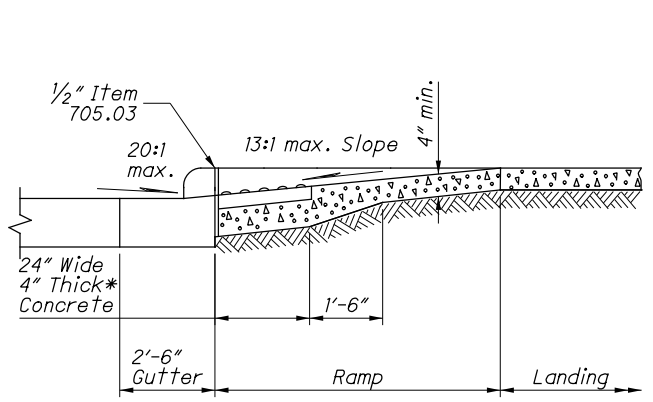

SECTION A-A
NORMAL DETAIL
See Sheet 2.

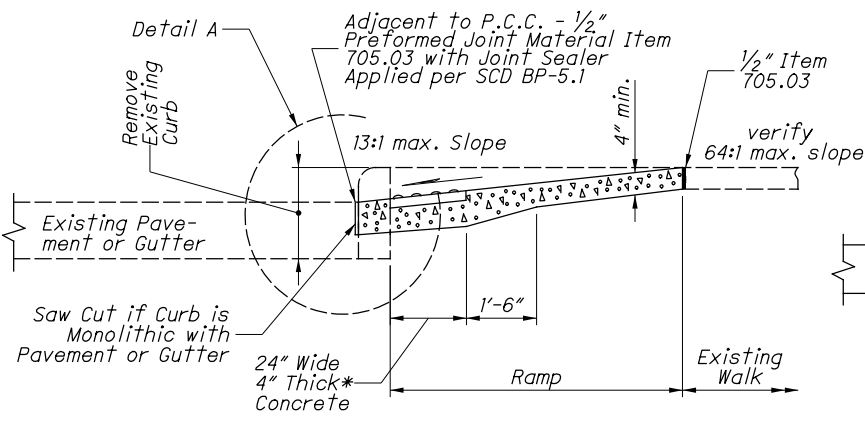

SECTION A-A
EXISTING WALK DETAIL
See Sheet 2.

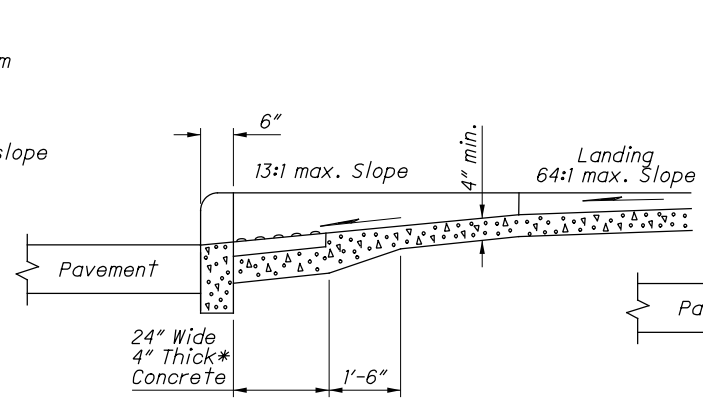

SECTION B-B
See Sheet 2.

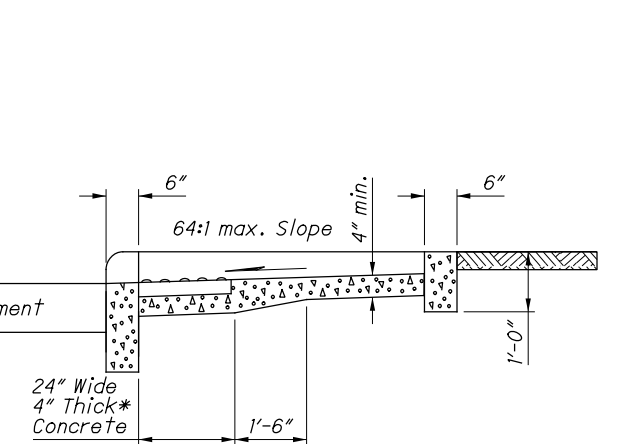

SECTION C-C
See Sheet 2.

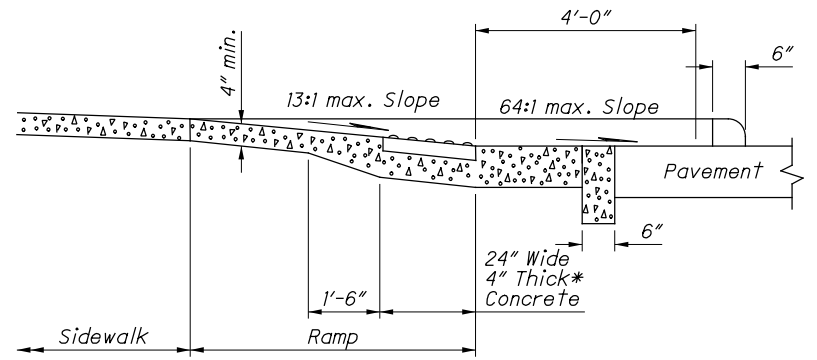

SECTION D-D
See Sheet 2.

*Where possible, pour ramp area integral with the curb, otherwise use 6" thick walk.

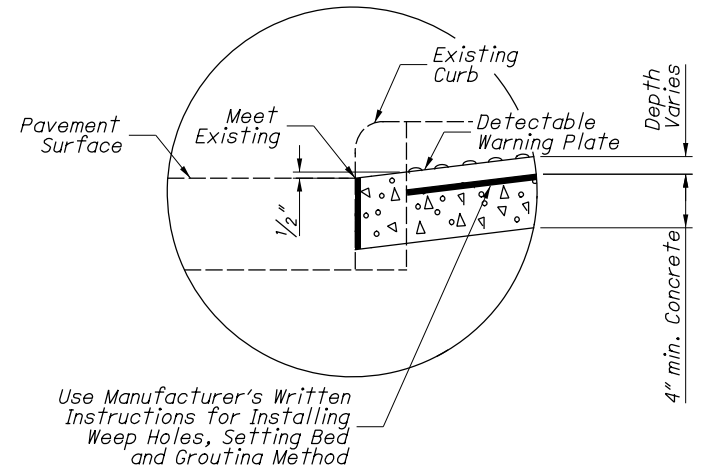

DETAIL A

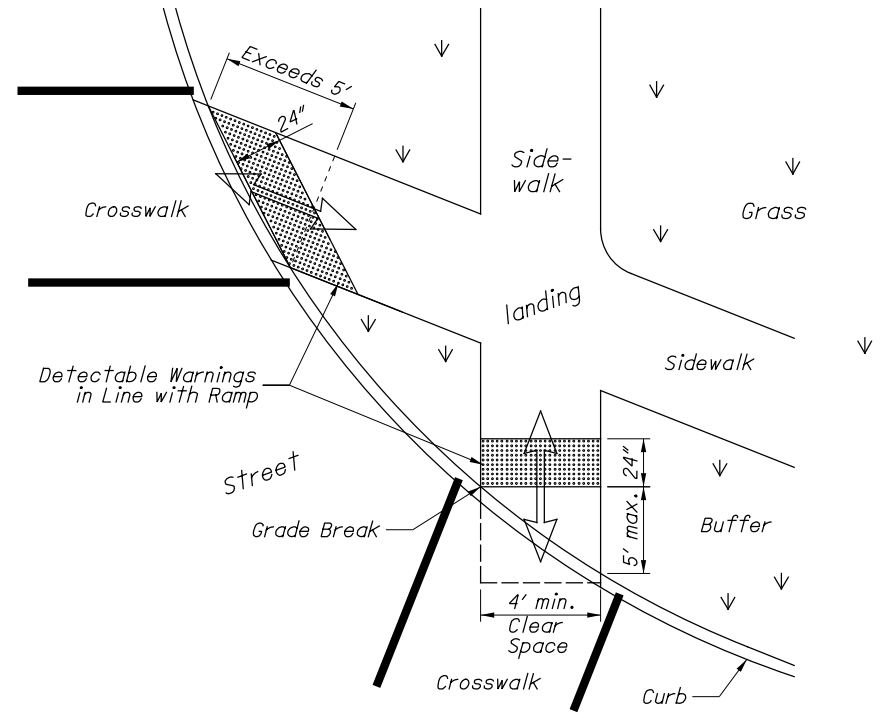

DETECTABLE WARNING ALIGNMENT

DETECTABLE WARNINGS NOTES

GENERAL: Detectable Warnings are a distinctive surface pattern of truncated domes which are detectable by cane or underfoot to alert people with vision impairments of their approach to streets and hazardous drop-offs.

PLACEMENT: Detectable warnings are to be installed at any location where pedestrians might cross paths with vehicular traffic lanes, such as the base of curb ramps or at blended curbs. A 24" strip of domes is to be installed for the full width of the ramp or walk. Typical street corner placement locations are shown on Sheet 1.

Some detectable warning products require a concrete border for proper installation. The concrete border should not exceed 2". Where the back of curb edge is tooled to provide a radius, the border dimension should be measured from the end of the radius.

The depth of concrete underneath detectable warning products shall be a minimum of 4". See DETAIL A.

ALIGNMENT: Truncated domes should be aligned with the primary direction of the ramp as shown on the DETECTABLE WARNING ALIGNMENT Detail. Normally the detectable warnings should be flush with the back of the curb, but for skewed conditions see DETECTABLE WARNING ALIGNMENT Detail. For non-standard layouts, detectable warning materials may have to be mitered and placed segmentally.

PRODUCTS & COLORS: Color of the detectable warnings should contrast with surrounding concrete walk and ramp. Black is not an acceptable color. Approved products and guidance on color may be found on the Office of Roadway Engineering Service's Detectable Warnings Approved List. Install products as per manufacturer's printed instructions.

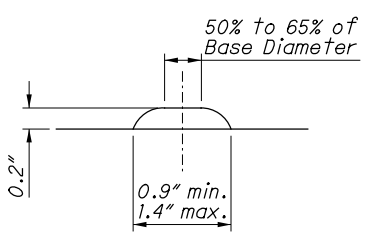

HEIGHT AND DIAMETER

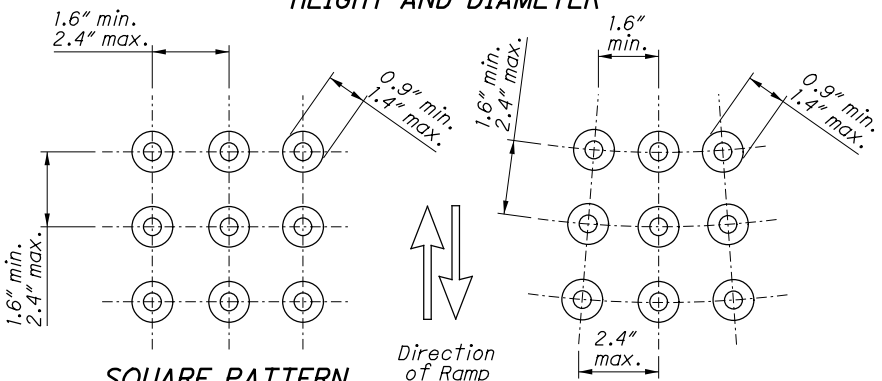

SQUARE PATTERN, PARALLEL ALIGNMENT
RADIAL ALIGNMENT

TRUNCATED DOMES DETAILS

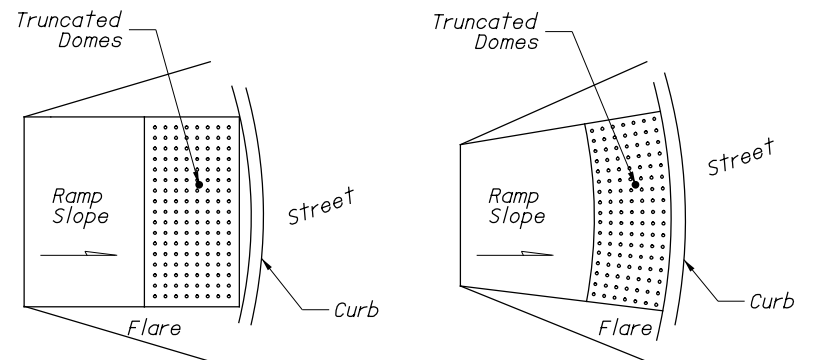

DOME ALIGNMENT ON RADIUS CURB

THIS DRAWING REPLACES BP-7.1 DATED 7-20-2018.

STANDARD ROADWAY CONSTRUCTION DRAWING
NEW CURB RAMPS
 (with Detectable Warnings)

SCD NUMBER
BP-7.1

OFFICE OF
 ROADWAY
 ENGINEERING

STDS.
 ENGINEER
 D. Fisher

STATE OF OHIO DEPARTMENT OF
 TRANSPORTATION ADMINISTRATOR

Brenton Bogard

REVISION DATE
 7-17-2020